

THIS DRAWING IS UNPUBLISHED. RELEASED FOR PUBLICATION, 19 .
 © COPYRIGHT 19 BY AMP INCORPORATED. ALL INTERNATIONAL RIGHTS RESERVED.

LOC	DIST	P	F	ZONE	LTR	DESCRIPTION	DATE	APPD
G	14				F	REV & REDRAWN PER 0720-0061-93	4-15-93	DA P

METRIC
 DIMENSIONS LISTED IN mm [INCHES]

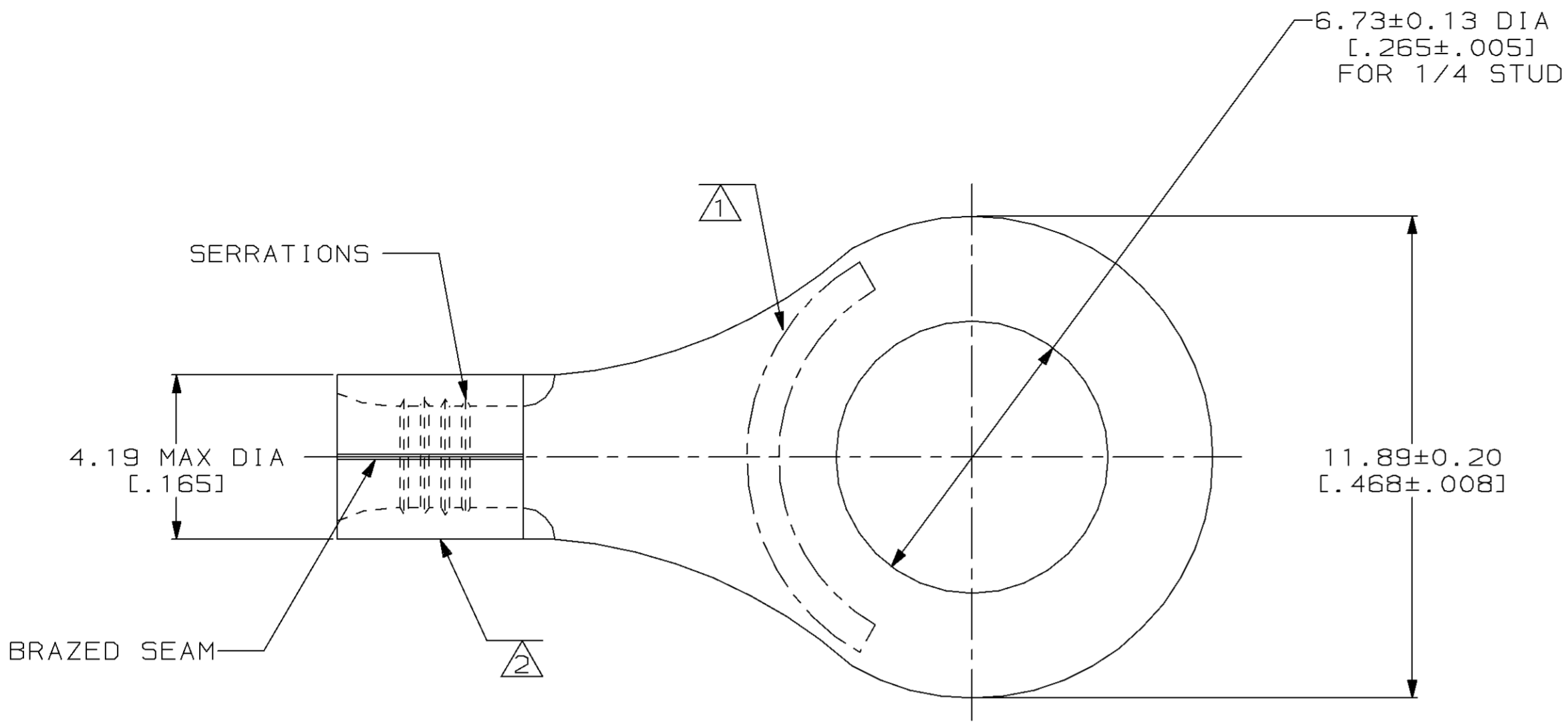

AMP WIRE RANGE	UL E13288 Listed
16-14 AWG SOLID OR STRANDED	NOT APPLICABLE
SR LR7189 Certified	MILITARY P/N AND CLASS
NOT APPLICABLE	NOT APPLICABLE

- ① STAMP AMP 16-14 APPROX AS SHOWN
- ② WIRE BARREL COLOR CODED ORANGE TO DENOTE NICKEL MATERIAL

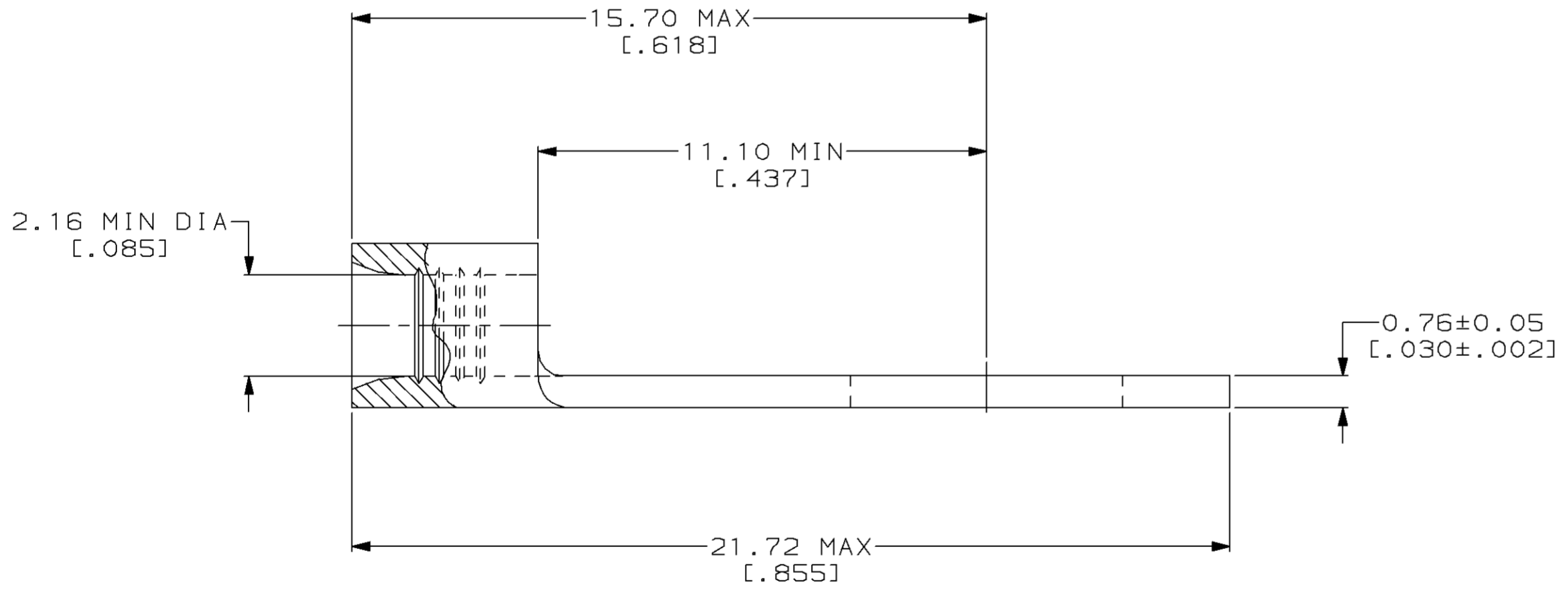

AMP INCORPORATED CUSTOMER SERVICE SYSTEMS		MAX RECOMMENDED OPERATING TEMPERATURE: 649°C MAX	DO NOT SCALE PRINT. UNLESS SPECIFIED DIMENSIONS IN mm [INCHES] TOLERANCES ON: 2 PLC DEC ± - 3 PLC DEC ± - ANGLES ± -	DR 4-15-93 TA BRINKMAN	AMP AMP Incorporated Harrisburg, PA 17105-3608
FOR ADDITIONAL PRODUCT INFORMATION OR COPIES OF DRAWINGS AND TECHNICAL DOCUMENTS	PRODUCT INFORMATION CENTER 1-800-522-6752	VOLTAGE RATING: NOT APPLICABLE	MATERIAL NICKEL PER ASTM B-162 ANNEALED	CHK 4-15-93 DA PATTERSON	
FOR APPLICATION TOOLING INFORMATION	TOOLING ASSISTANCE CENTER 1-800-722-1111	WIRE CROSS SECTIONAL AREA RANGE: 1.04-2.62mm ² [2,050-5,180] CIR MILS SOLID OR STRANDED	FINISH -	APPD 4-15-93 DE MILLER	SIZE ③ 00779
FOR ORDER ENTRY	1-800-526-5142	THIS DRAWING IS A CONTROLLED DOCUMENT FOR AMP INCORPORATED. IT IS SUBJECT TO CHANGE AND THE CONTROLLING ENGINEERING ORGANIZATION SHOULD BE CONTACTED FOR THE LATEST REVISION.		APPD 4-15-93 JL MECKLEY	DRAWING NO ③=322339
AMP 1471-6 REV 3-92				PRODUCT SPEC -	SCALE 8:1
02 AUG 1993 10:06:03 AMP26463 <US128A>DEPT1123>DWG1123>U.STRATO-THERM>U. TERMINALS				APPLICATION SPEC -	SHEET 1 OF 1